

# MotorGuide® REPAIR PARTS

**Model:**  
**RT27**

**SPECIFICATIONS:**

Year	1999
Thrust	27LBS
Volts	12VDC
Amp Draw	0 to 48 amps
Mount	31 Transom
Speeds	5 For/2 Rev

**PARTS ORDERING & TECH ASSISTANCE**

MotorGuide Consumer Relations  
 Phone 918-831-6989  
 Fax 800-982-8093

*Returned Goods must be accompanied with a Returned Goods Authorization. Contact MotorGuide Consumer Relations to obtain RGA.*

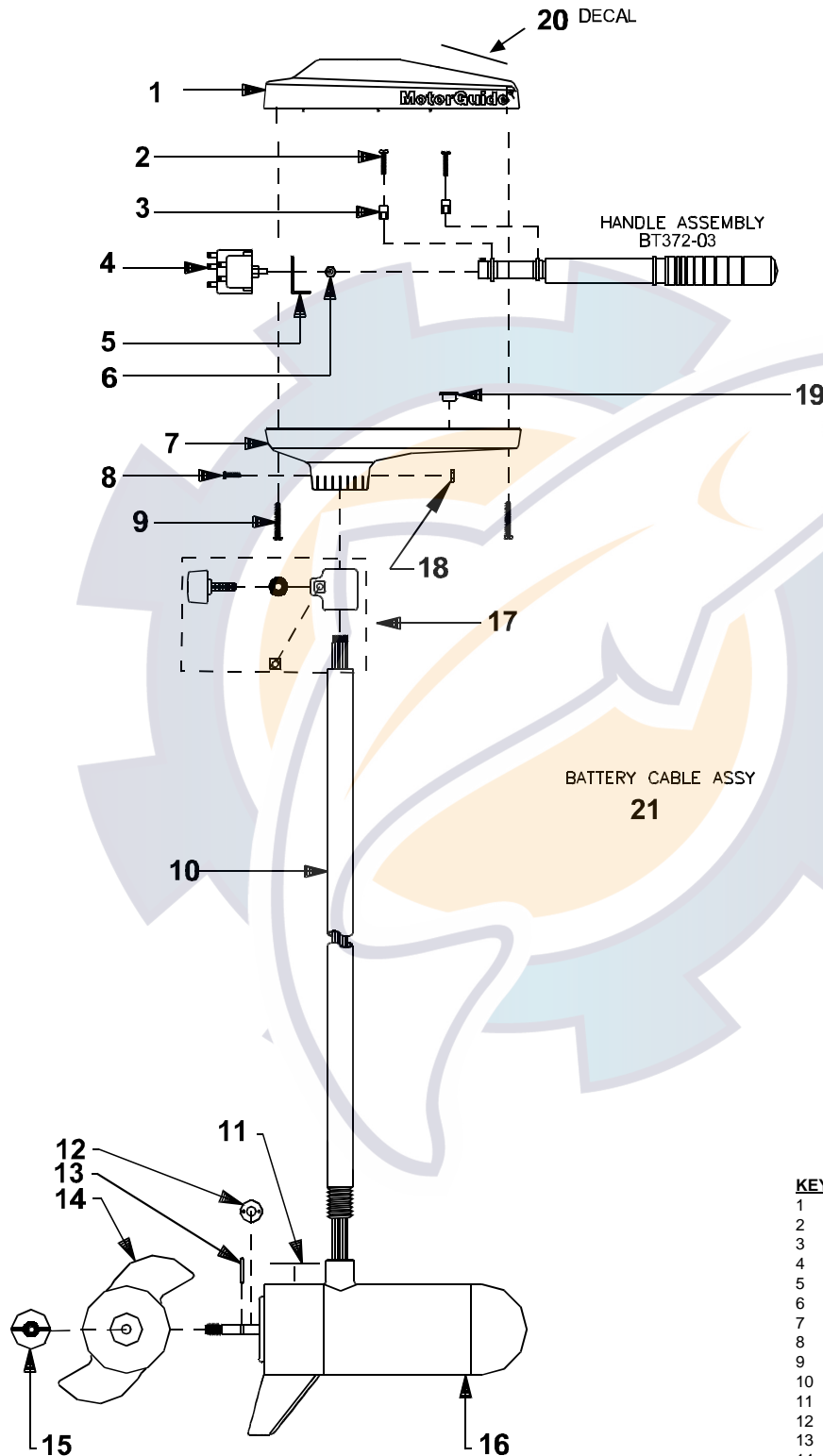

KEY	DESCRIPTION	PART #
1	COVER BLACK	FR053-11
2	8x1 3/8 SCREW	AR133-01
3	RETAINER CLAMP	AR036-01
4	ROTARY SWITCH	KT150-01
5	BRACKET	AT155-02
6	NUT	AT098-01
7	T/H BASE BLACK	FR004-06
8	1/4X20 HEX HEAD	XT134-02
9	8X 1 3/8 SCREW	AR133-01
10	H/O COLUMN	MT049-11
11	LOWER UNIT DECAL	ET060-04
12	MONOFILAMENT WASHER	AR175-01
13	PROP DRIVE PIN	BR102-01
14	PROP/ 2 BLADE	FF124-04
15	PROP NUT	AR099-01
16	MOTOR	HF397-04
17	DEPTH COLLAR ASSY	AR158-01
18	NYLON LOCK NUT	XT098-02
19	GROMMET	GR019-03
20	DECAL	PT053-19
21	BATTERY CABLE ASSY	TT328-03

LOWER UNIT BREAKDOWN

Model:  
**RT27**

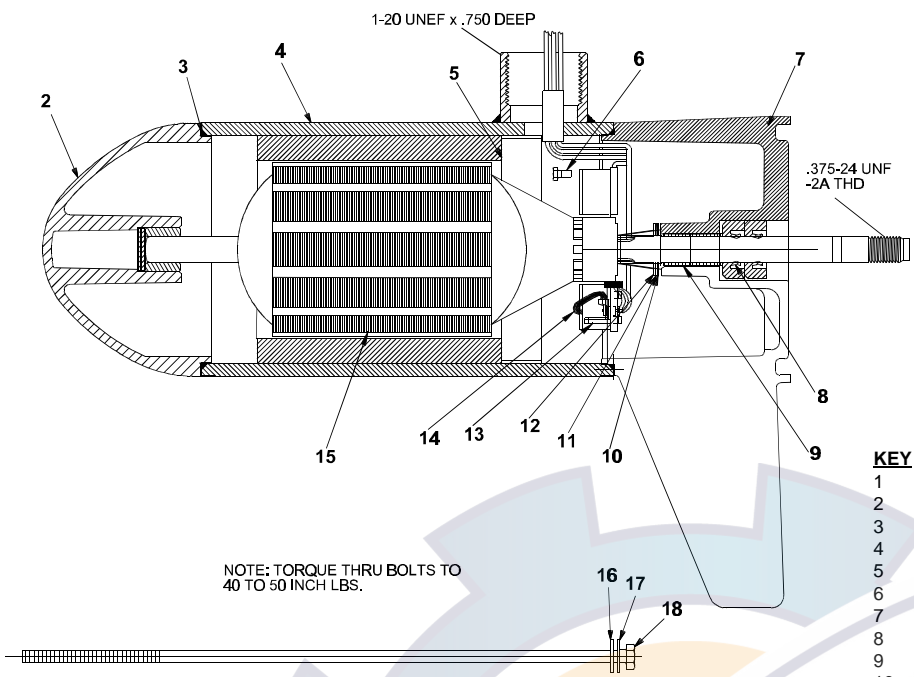

KEY	QTY	DESCRIPTION	PART NO.
1	X	MOTOR	HF397-04
2	1	NOSE CAP	FF3212-01
3	2	O RING SEAL	HF217-01
4	1	HOUSING ASY	HF3210-01
5	1	RETAINER	JF233-01
6	2	BRUSH CARD SCREW	MR228-01
7	1	COMM CAP	FF3205-01
8	2	SHAFT SEAL	MR223-01
9	1	BEARING	MR206-01
10	1	NYLATRON WASHER	MR226-01
11	1	WASHER	MR227-01
12	1	E RING	MR219-01
13	2	BRUSH SPRINGS	MR214-02
14	1	BRUSH ASY LESS SPRING	FF3201-01
15	1	ARMATURE 3"	HF3207-02
16	4	STATIC SEAL	MR222-01
17	4	THRU BOLT WASHER	MR216-01
18	2	THRU BOLT	MR218-06

WIRING

